

Characteristics:

General Description:

The single and dual channel Eurocard Temperature Converter E1079 S and E1079 D, converts a low level dc signal from millivolt, thermocouples or RTD temperature sensors, located in Hazardous Area, into a current or voltage output signal, to drive a Safe Area load. Output signal can be linear or reverse.

Function:

1 or 2 channels I.S. input for millivolt, thermocouples or 3, 4 wire resistance thermometers or transmitting potentiometers, provides 3 port isolation (input/output/supply) and current or voltage output signal.

Signalling LED:

Power supply indication UB (green), Burnout indication A-B (red).

Configurability:

Totally Software configurable, no jumpers or switches, Input sensor, Connection mode, Burnout operation, mA or V output signal, linear or reverse, by a GM Pocket Portable Configurator PPC 1090, powered by the card. To operate PPC1090 refer to instruction manual.

Test Points:

Analog output signal.

EMC:

Fully compliant with CE marking applicable requirements (tolerant to a 20 ms line interruption).

Front Panel:

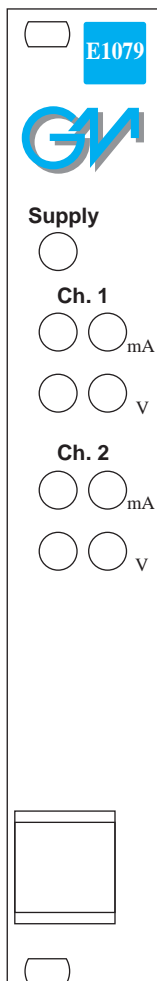

- mV, Thermocouples, RTD or Transmitting Potentiometers Input Signal.
- 0/4-20 mA, 0/1-5 V, 0/2-10 V Output Signal Temperature Linear or Reverse.
- Output for burnout detection.
- Software programmability.
- High Accuracy, μ P controlled A/D converter.
- Three port isolation, Input/Output/Supply.
- EMC Compatibility to EN61000-6-2, EN61000-6-4.
- Tolerant to a 20 ms line interruption and Inrush current limited.
- ATEX Certification.
- High Reliability, SMD components.
- High Density, two channels per card.
- Simplified installation using standard Eurocard plug-in connector.
- GM International Standard Bus Pin Layout.
- 250 Vrms max. voltage applied to the instruments associated with barrier.

Technical Data:

Supply (UB): 24 V nom (20 to 30 V) reverse polarity protected ripple within voltage limits ≤ 5 Vpp.
Current consumption @ 24 V: 75 mA for 2 channels E1079D, 50 mA for 1 channel E1079S with 20 mA output typical.
Max. power consumption: 2.3 W for 2 channels, 1.6 W for 1 channel with 30 V supply voltage, overload condition and PPC1090 connected.

Isolation (Test Voltage):

I.S. In/Out 1.5 KV; I.S. In/Supply 1.5 KV; I.S. In/I.S. In 500 V; Analog Out/Analog Out 500 V; Analog Out/Supply 500 V.

Input: millivolt or thermocouple type B, E, J, K, L, N, R, S, T, U, Lr or 3, 4 wire RTD Pt 100, Pt 200, Pt 300 to DIN43760, Pt100 (0.3916), Ni 100 or Pt100, Pt50, Cu100, Cu53, Cu50 (russian standard) or 3 wire transmitting potentiometer (50 Ω to 20 K Ω).

Integration Time: 500 ms.

Resolution: 5 μ V on mV or thermocouple, 1 μ V thermocouple type B, R or S, 20 m Ω on RTD, 0.05 % on Potentiometer.

Visualization: 0.1 $^{\circ}$ C on temperature, 10 μ V on mV, 0.1 % on Potentiometer

Input range: within rated limits of sensor (-10 to + 80 mV).

Measuring current: ≤ 0.5 mA.

Line resistance compensation: ≤ 10 Ω .

Thermocouple Reference junction compensation: automatic by externally connected sensor (option 91 separately ordered).

Burnout: enabled or disabled. Analog output can be programmed to detect burnout condition with downscale or highscale forcing.

Output: 0/4 to 20 mA, on max. 600 Ω load source mode, current limited at 22 mA or 0/1 to 5 V or 0/2 to 10 V signal, limited at 11 V.

Resolution: 2 μ A current output or 1 mV voltage output.

Transfer characteristic: linear or reverse on mV or transmitting potentiometer, temperature linear or reverse on temperature sensors.

Response time: 100 ms (10 to 90 % step change).

Output ripple: ≤ 20 mV rms on 250 Ω load.

mA Test points: Ammeters with Ri ≤ 10 Ω .

V Test points: Voltmeter with Ri ≥ 1 M Ω .

Performance: Ref. Conditions 24 V supply, 250 Ω load, 23 ± 1 $^{\circ}$ C ambient temp.
Input: Calibration and linearity accuracy: $\leq \pm 20$ μ V on mV or thermocouple, 200 m Ω on RTD, 0.2 % on Potentiometer or ± 0.05 % of input value.

Temperature influence: $\leq \pm 1$ μ V, 10 m Ω , 0.01 % or ± 0.01 % of input value for a 1 $^{\circ}$ C change.

Ref. junction compensation influence: $\leq \pm 1$ $^{\circ}$ C (thermocouple sensor).

Analog Output: Calibration accuracy: $\leq \pm 0.1$ % of full scale.

Linearity error: $\leq \pm 0.05$ % of full scale.

Supply voltage influence: $\leq \pm 0.05$ % of full scale for a min to max supply voltage change.

Load influence: $\leq \pm 0.05$ % of full scale for a 0 to 100 % load resistance change.

Temperature influence: $\leq \pm 0.01$ % on zero and span for a 1 $^{\circ}$ C change.

Compatibility:

CE CE mark compliant, conforms to 94/9/EC Atex Directive and to 89/336/CEE EMC Directive.

Environmental conditions: Operating: Temperature limits -20 to + 60 $^{\circ}$ C, relative humidity max 90 % non condensing, up to 35 $^{\circ}$ C.

Storage: Temperature limits - 40 to + 80 $^{\circ}$ C.

Safety Description: II (1) G D [EEx ia] IIC associated electrical apparatus.

$U_o = 10.75$ V, $I_o = 8.63$ mA, $P_o = 23.2$ mW

at terminals z2-z4-z6-z8 and d2-d4-d6-d8.

$U_m = 250$ Vrms, -20 $^{\circ}$ C $\leq T_a \leq 60$ $^{\circ}$ C.

Approvals: DMT 01 ATEX E 042 X conforms to EN50014, EN50020.

Mechanical: Eurocard 100 x 160 mm with 4TE, 3 HE front panel mountable in 19" rack, any installation position.

Weight: about 200 g.

Connection: DIN 41612 Form F 32 pole male connector rows d, z. Requires a female mating connector.

Location: Safe Area installation.

Protection class: IP 20 when installed in 19" rack.

Parameters Table:

Safety Description	Maximum External Parameters			
	Group Cenelec	Co (μF)	Lo (mH)	L/R (μH/Ω)
Terminals z2-z4-z6-z8, d2-d4-d6-d8				
Uo = 10.75 V	II C	2.14	477	1530
Io = 8.63 mA	II B	15.00	1909	6130
Po = 23.2 mW	II A	66.00	3819	12260

Ordering Information:

Model:

E1079

1 channel
2 channels

S
D

Input types, burnout conditions, output types, output range are programmable by the GM Pocket Portable Configurator type PPC 1090. If the above information are provided with the Purchasing Order, the unit will be configured accordingly, otherwise the unit will be supplied, by default, with the following parameters: Input Type: -10 to +80 mV - Output Type: 4-20 mA - Burnout: highscale. The plate will record the unit type, serial number, function diagram and terminal block layout for connections.

Note: for thermocouple sensor input, the Reference Junction Compensator is required. It has to be ordered as "Option 91". It will be supplied separately and it has to be connected at the input Terminal Blocks as indicated in the function diagram.

Eurocard Layout:

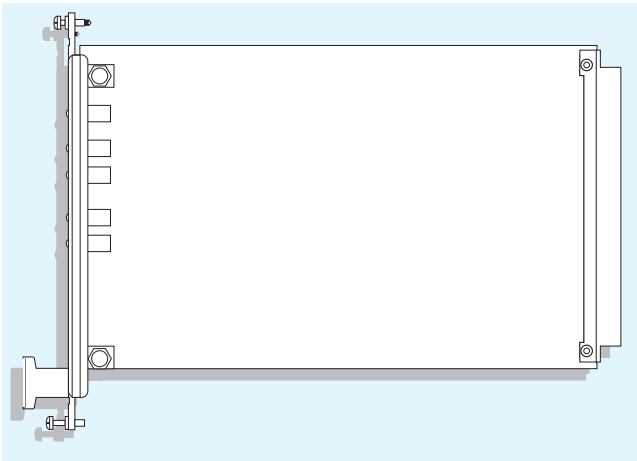

Connector Pin Layout:

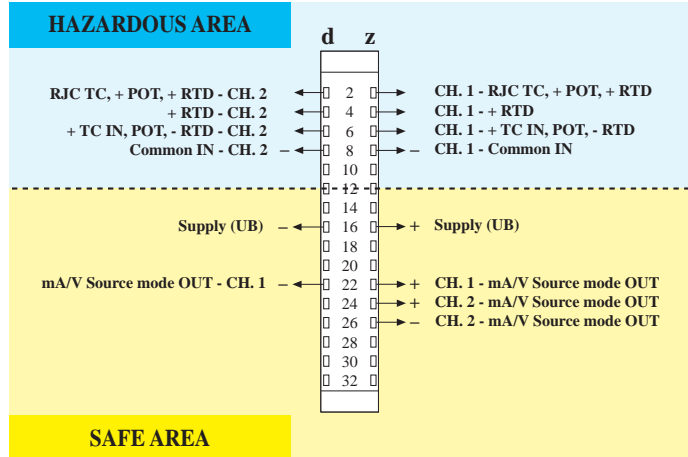

Function Diagram:

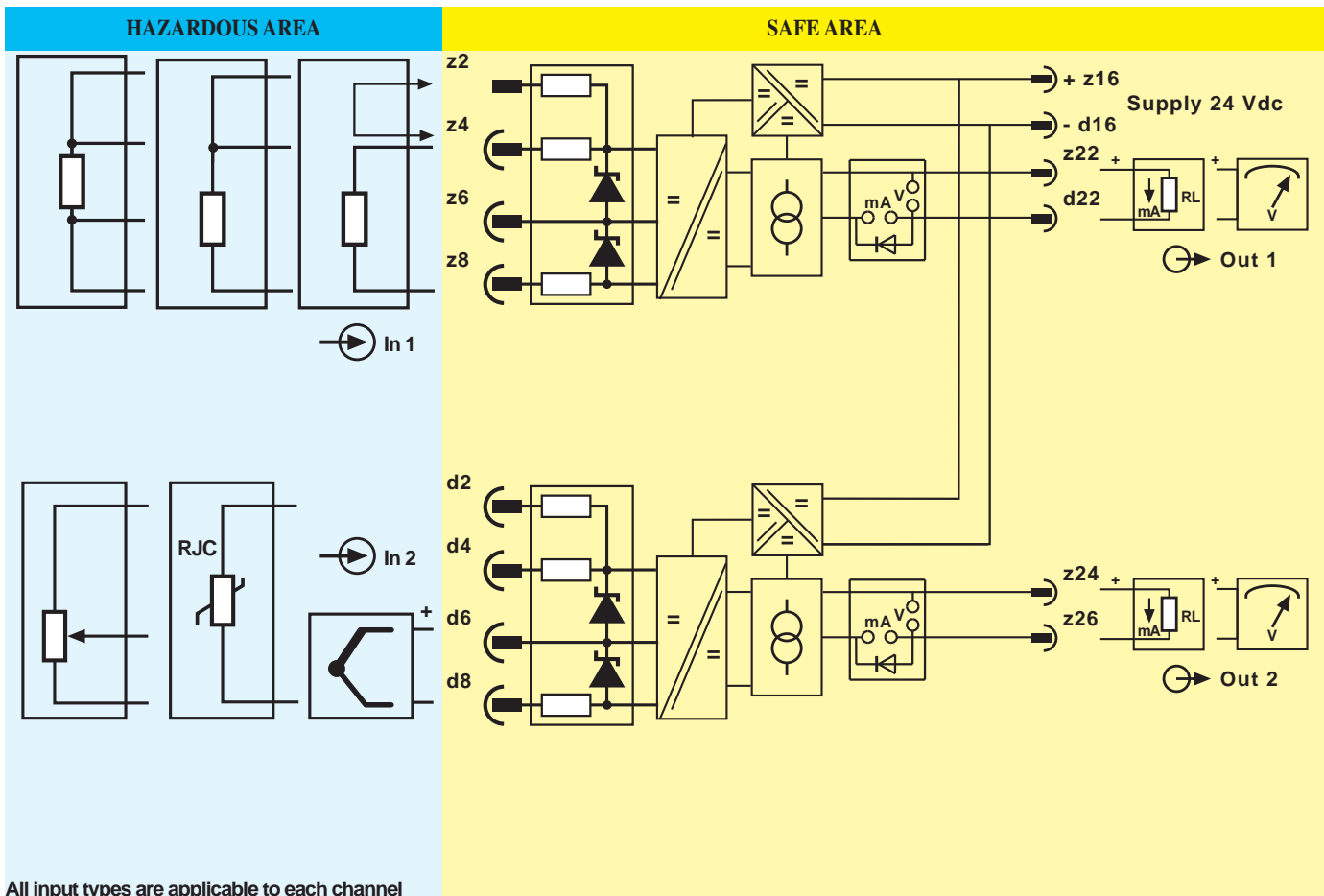

All input types are applicable to each channel