

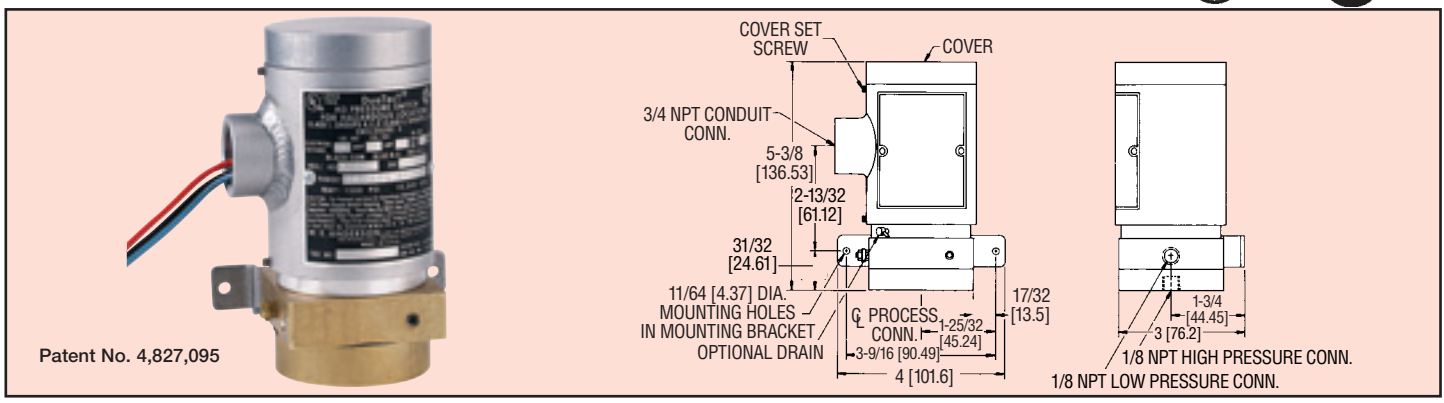

Series H3

# Explosion-Proof Differential Pressure Switches

Setpoints from 10" w.c. to 200 psid — Rated 1500 psig, Weatherproof



Patent No. 4,827,095

**Explosion-proof**, heavy duty, industrial unit has patented and unique new design which provides sensitivity to differential pressures as low as 10 inches of water (254 mm w.c.), yet handles total pressure of 1500 psi (103 bar). Unit yields deadbands approximately 5% of range, with zero setpoint shift due to variation in working pressures. Friction is minimized and repeatability increased by allowing range spring to act directly on diaphragm plate. Rolling diaphragm design maintains constant effective area to further reduce friction. Diaphragm is allowed to "seat", allowing application of full rated pressure, up to 1500 psi (103 bar), on either high or low pressure port, without damage. Special over-travel feature prevents overtightening of range adjust screw. Choose optional brass chamber for water and water-based fluids or 316 stainless steel for harsher applications.

**SPECIFICATIONS**

- Wetted Materials:** See pressure chamber and diaphragm material in model chart.
- Temperature Limit:** -4 to 220°F (-20 to 104°C), ATEX: -20 to 90°C (-4 to 194°F).
- Pressure Limit:** 1500 psig (103 bar).
- Enclosure Rating:** See ratings chart.
- Switch Type:** SPDT or DPDT snap switch.
- Electrical Rating:** 5A @ 125/250 VAC, 30 VDC.
- Electrical Connections:** See model chart.
- Conduit Connection:** 3/4" female NPT.
- Process Connection:** 1/8" female NPT.
- Mounting Orientation:** Vertical.
- Set Point Adjustment:** Internal screw.
- Weight:** 4 lb, 2 oz (2 kg).
- Deadband:** Approximately 5% of range.
- Agency Approvals:** UL, CSA, CE, and ATEX see ratings chart.

**STOCKED MODELS** in bold

- Model H3A-1SL
- Model H3A-2SL
- Model H3A-3SL
- Model H3B-1SL
- Model H3B-2SL
- Model H3B-3SL
- Model H3S-1SL
- Model H3S-2SL
- Model H3S-3SL
- A-610-Pipe Mounting Kit for 1-1/4 to 2" pipe**

**Model Chart - Series H3**

Example	H3	S	2	S	C	MV	
							H3S-2SC-MV Differential Pressure Control; 316 SS pressure chamber and Viton® diaphragm; weatherproof and ATEX; SPDT snap action switch with gold contacts; fixed deadband, automatic reset; adjustable range 0.5-15 psid
<b>Construction</b>	H3						Series designator, weatherproof and explosion-proof
<b>Pressure Chamber &amp; Diaphragm Material (Wetted)</b>		A					Aluminum chamber with Nitrile diaphragm
		B					Brass chamber with Nitrile diaphragm
		S					316 SS chamber with Viton® diaphragm
<b>Adjustable Operating Range</b>			1				Adjustable range 10-180 in. w.c. (2.48-44.78 kPa)
			2				Adjustable range 0.5-15 psid (0.3-1 bar)
			3				Adjustable range 5-70 psid (.34-4.8 bar)
			4				Adjustable range 10-200 psid (.7-13.8 bar)
<b>Deadband approximately 5% of range</b>							Maximum pressure for all ranges is 1500 psi (103 bar)
<b>Circuit (Switch) Options</b>				S			SPDT snap action switch rated 5A @ 125/250 VAC, 30 VDC
				D			DPDT snap action switch rated 5A @ 125/250 VAC, 30 VDC
<b>Electrical Connection</b>					L	T	18 AWG x 18 inch lead wires UL, CSA approved internal terminal block
<b>Options</b>						C	ATEX approved internal terminal block
						DRAIN	Housing with drain - allows condensate to be drained from inside enclosure (meets NEMA 3 instead of 4X)
						MV	Gold contacts on snap switch for dry circuits rated 1A @ 125 VAC, 1A resistive or 0.5 A inductive @ 30 VDC
						VIT	Viton® diaphragm option where not standard

HAZARDOUS LOCATION/WEATHERPROOF RATINGS			
MODEL	UL	CSA	Directive 94/9/EC ATEX Compliant
H3 _ _ _ C	—	—	CE 0344 Ex II 2 G EEx d IIB -20°C ≤ T amb ≤ 75°C T6 EC-Type Certificate No. KEMA 03ATEX 2584
H3 _ _ _ L H3 _ _ _ T	Cl. I, Gr.B, C & D Cl. II, Gr.E, F & G NEMA 4X	Cl. I, Gr.B, C & D Cl. II, Gr.E, F & G NEMA 4	—
H3 _ _ _ C-DR	—	—	CE 0344 Ex II 2 G EEx d IIB -20°C ≤ T amb ≤ 75°C T6 EC-Type Certificate No. KEMA 03ATEX 2584
H3 _ _ _ L-DR	Cl. I, Gr.B, C & D Cl. II, Gr.E, F & G NEMA 3	—	—

